



**Robinson/Kirshbaum Industries, Inc.**

**Custom Beverage Technologies**



## SAC 403 Milk Dispensing System

*“Putting a chill on milk...straight out of the box”* exemplifies the next evolutionary step in selling milk, milk related and other beverage products. Our systems approach redefines for the coffee industry the cost saving concepts behind true bulk dispensing, quality enhanced point of dispense temperature controlled, and instantaneous product brand-name appeal. Systems that draw upon years of proven technological and advertising capability, engineered to enhance beverage sales and marketing.

### **The Coffeehouse Experience**

**How does dispensing milk benefit coffee bars?** The simple truth is, it's simple and fast, cuts down on repetitive motions saving time, protecting health, creating cleaner operations, all while lowering costs and improving profits. When it comes to marketing beverages, dispensing easily promotes good customer experiences that are always rewarded in increased visits and profitable sales!

**Rethinking coffee bar operations.** Picture having a remote milk dispensing tower sitting on one or both sides of your espresso machine making it easier for your baristas to serve up all those coffee and specialty drinks quickly, opening up advantages in terms of refrigeration space and the reduction of clutter at the coffee bar. Less bending over, hand/wrist pouring and the restocking of awkward milk containers that slows production, leads to accidents, higher insurance liability and premiums, which are all unnecessary costs eating away at your profits. Further advantages are quick and clean restocking with greater on-line volume located in the back storage area that definitely promotes increased production during peak rushes by providing your valued customers more attention, crucial to the tasks of taking and filling orders quicker so as to serving more drinks efficiently.

**Maximizing on self-serve efficiency.** Customers are usually in a rush. Improving customer handling of milks and creamer products by adding a self-serve dispensing tower makes it easier, faster, safer, and cleaner to operate. By running a refrigerated remote trunk line from the back room storage we can branch off to different dispensing tower locations often sharing product lines further increasing product volume while trimming down product and handling costs on-hand. Besides, most customers find self-dispensing fun!

**Continued evolution of drink-taste trends opens up more options and savings that just make sense.** SAC remote dispensing systems offer more savings options worth considering when other beverages are considered. Iced teas, juices, smoothies, specialty coffee and milk based beverage creations can all be dispensed in a cost saving manner that utilizes less refrigeration storage, reduced handling and inventory concerns. Add drinks that appeal to the promotion of health that can catch the eye of parents and kids. Drinks are poured ice cold and fresh to maximize on quality. Our drink systems offer features that can help promote a healthier greener planet. Along with lowering refrigeration and electrical requirements and the use of air to drive the dispensing pumps, when selling dispensed drinks in biodegradable cups reduces environmental aspects pertaining to glass and plastic containers in regards to manufacture and disposal.

**Better control means safer operations.** Bag n box containers are the most sanitary, easiest to use and maintain bulk packaging on the market today. BIB's are offered in various sizes to accommodate pre-mix and/or mixed ratio product blending beverage options that all work well with our SAC systems. Inventory control can feature dates, manufacture plant, bar codes or any number of vital statistics that your operations require on each bib container. The SAC 403 Milk Dispensing Systems were NSF tested and certified under Standard 18 – General Beverage Dispensing Equipment and Standard 20 – Bulk Milk Dispensing Equipment, assuring that system components and the simple three step BIB line cleaning procedure is safe and easy towards maintaining the established standards of cleanliness, just like the rest of your coffee bar equipment.

**Other Coffee sales opportunities are waiting.** A SAC beverage systems approach is ideal for schools, colleges, university, cruise ships, hotel, casino, health care, military cafeteria operations along with airports, theme parks, and fast-food restaurants. Fast pouring dispensing systems open up possibilities for sporting events and concert venues where stand alone or co-branding with other beverage products can keep handling costs minimal while marketing your image and boosting profits. SAC 403 Dispensing Systems can even be outfitted on portable carts and shipped and installed overseas for international locations.

**SAC 403 Remote Milk/Multi-Beverage System**

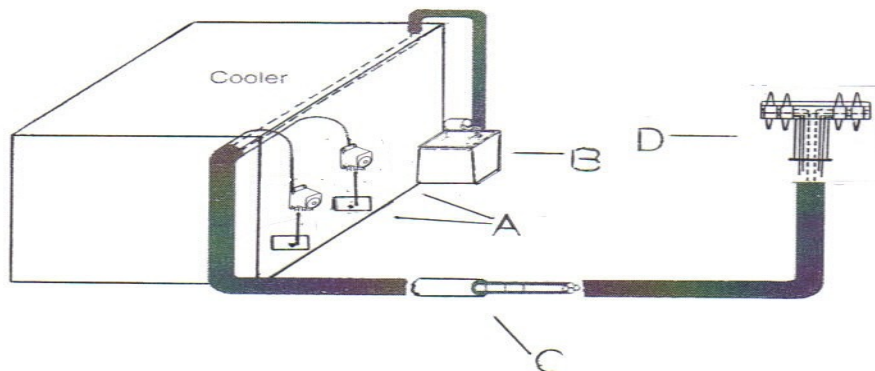

***“YOUR BEVERAGE BUSINESS IS OUR ONLY BUSINESS”***