



**Robinson/Kirshbaum Industries, Inc.**

**Custom Beverage Technologies**



## SAC 403 Milk Dispensing System

*“Putting a chill on milk...straight out of the box”* exemplifies the next evolutionary step in selling milk, milk related and other beverage products. Our systems approach redefines for campus food service operations the cost saving concepts behind true bulk dispensing, quality enhanced point of dispense temperature controlled, and instantaneous product brand-name appeal. Systems that draw upon years of proven technological and advertising capability, engineered to enhance beverage sales and marketing.

### **Campus Food Service Catering**

**Rethinking operations.** Centralized back of the house storage that allows for refrigerated glycol chilled trunk line leads to fan out to many dispensing locations will ease congestion and keep customer services moving faster. More product on-line means fewer run outs during peak periods, but in the event a change-out need occur, it can be quickly handled away from the customers keeping employee and customer both safer. Further advantages are quick and clean restocking with greater on-line volume located in the back storage area that definitely promotes increased production during peak rushes by providing your valued customers more attention, crucial to the tasks of taking and filling orders quicker so as to serving more drinks efficiently. Dispensing is fast and easy and our systems can be set for the products optimum coldest serving temperature, assuring customer satisfaction that leads to repeat sales. There is nothing better than drinking an extra cold beverage to promotes quality drink recognition.

**Maximizing on self-serve efficiency.** Students are usually in a rush. Improving student handling of milks and other beverage products by offering self-serve dispensing makes it easier, faster, safer, and cleaner to operate. By running a refrigerated remote trunk line from the back room storage we can branch off to different dispensing tower locations often sharing product lines further increasing product volume while trimming down product and handling costs on-hand. Besides, students find self-dispensing fun!

**How does dispensing milk benefit coffee bars?** The simple truth is, it's simple and fast, cuts down on repetitive motions saving time, protecting health, creating cleaner operations, all while lowering costs and improving profits. When it comes to marketing beverages, dispensing easily promotes good customer experiences that are always rewarded in increased visits and profitable sales!

**Continued evolution of great tasting beverages opens up more options and savings that just make sense.** SAC remote dispensing systems offer more savings options worth considering when other beverages are considered. Iced teas, juices, liquid smoothies, specialty iced coffee and milk based beverage creations can all be dispensed in a cost saving manner that utilizes less package refrigeration storage, reducing handling and inventory concerns. Many drinks can appeal to the promotion of health. Your drinks are delivered ice cold and fresh to maximize on quality. Our drink systems offer features that can help promote a healthier greener planet by the use of air to drive the dispensing pumps, and when selling dispensed drinks in biodegradable cups helps reduce environmental aspects pertaining to glass and plastic containers in regards to manufacture and disposal.

**Better control means safer operations.** Bag n box containers are the most sanitary, easiest to use and maintain bulk packaging on the market today. BIB's are offered in various sizes to accommodate pre-mix and/or mixed ratio product blending beverage options are all SAC system options. Inventory control can feature dates, manufacture plant, bar codes or any number of vital statistics that your operations require on each bib container. The SAC 403 Milk Dispensing Systems were NSF tested and certified under Standard 18 – General Beverage Dispensing Equipment and Standard 20 – Bulk Milk Dispensing Equipment, assuring that system components and the simple four step BIB line cleaning procedure is safe and easy towards maintaining the established standards of cleanliness, just like the rest of your beverage and food service equipment.

**Even More options to come.** Soon our remote refrigerated dispensing technology will be featured on portable carts that can be order dressed up to speak the customized messages that you desire for your students and facility in catching their attention. Further, our systems stainless steel tower outer wrap can be ordered in a wide range of colors, surface finishes, surface designs and textures to add eye appeal to promote further attraction. Just think, you could offer milk and other health drinks at all types of school functions, off-campus catering, sporting events, and even convenient well traveled campus locations to meet the needs of the students on the run between classes. All our equipment is designed for flexibility.

**SAC 403 Remote Milk/Multi-Beverage System**

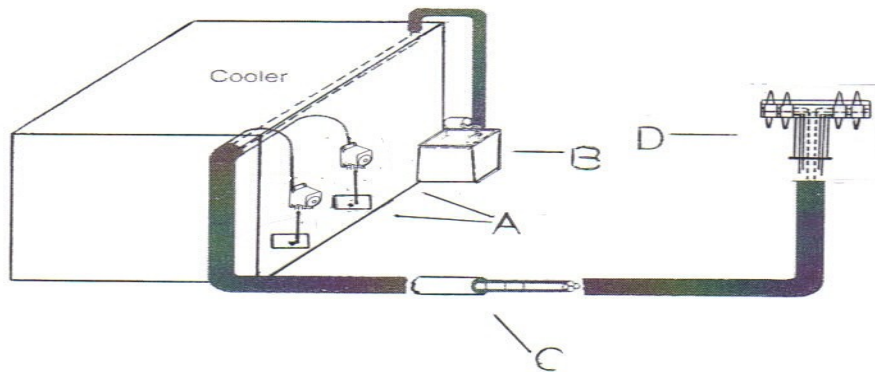

***“YOUR BEVERAGE BUSINESS IS OUR ONLY BUSINESS”***