

BULK MILK ON-DRAFT

NOTHING IS BETTER THAN CHUGGING AN ICE COLD MILK DISPENSED FROM A REMOTE DRAFT SYSTEM!

MILK BASED DRINKS FROM DRAFT MILK SYSTEMS WILL BE DISPENSED AT THEIR HIGHEST QUALITIES – PURE, FRESH, AND ICE COLD!

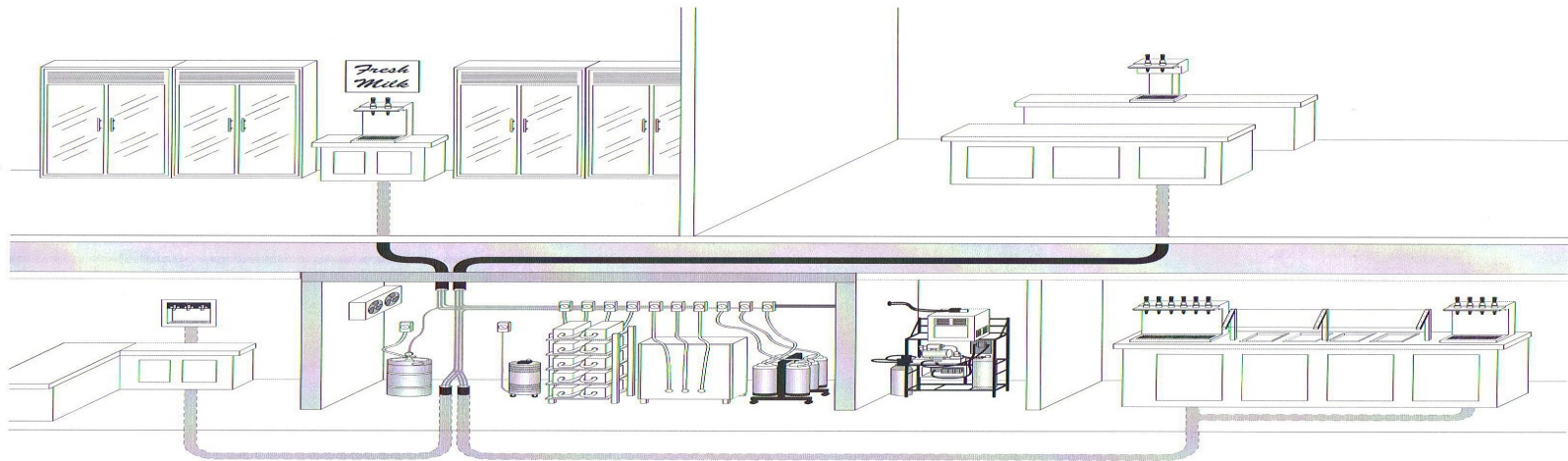

AS DISPENSING MILK GROWS IN POPULARITY, CONSUMERS WILL PERCEIVE BULK MILK AT ITS BEST BECAUSE THE PROPERTIES OF DRAFT MILK DISPENSING ENHANCES THE DRINKING EXPERIENCE.

SYSTEM DISPENSED DRAFT MILK SHARES IN A HISTORY OF EXPERIENCE AND GREAT TASTE BOOSTING THE “HEALTHY FOR YOU” IMAGE THAT MILK PRODUCTS PROMOTE AND REPRESENT.

RETAILER CONSIDERATIONS WITH DRAFT MILK SYSTEMS

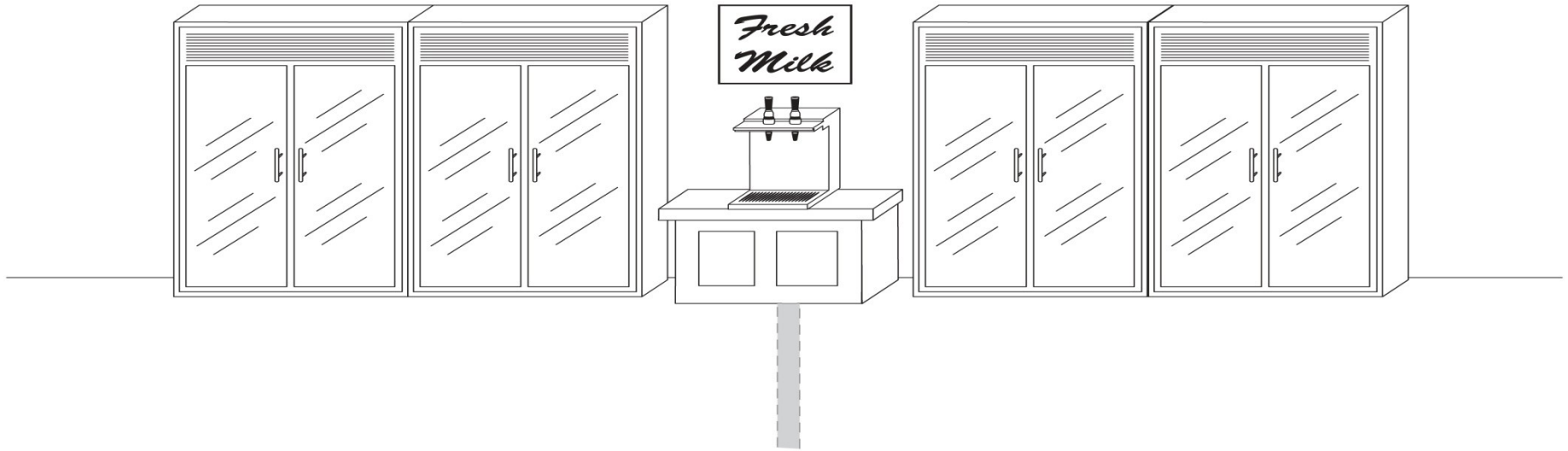

- ✓ RATIO-MIXED FLAVORED BEVERAGES INCREASES SELECTION, MINIMIZES STORAGE, LOWERS HANDLING, INCREASES VOLUME SOLD ALL WHILE BOOSTING STORE PROFITS.
- ✓ DISPENSED DRAFT MILK ATTRACTS CURIOSITY, CREATES LOYAL CUSTOMERS THAT WILL BUILD A HIGHER VISIT FREQUENCY.
- ✓ INSTANT ADVERTISING WITH FOCUSED PRODUCT CHOICES THAT SPEEDS UP CUSTOMER SELECTION.
- ✓ SERVING DRAFT MILK PROMOTES A LOWERED IMPACT ON THE ENVIRONMENT – FEWER DELIVERIES, REDUCED ELECTRICAL USAGE, LESS TRASH.
- ✓ A MULTITUDE OF DRINK OPTIONS CAN BE OFFERED – FLAVORED MILKS, SMOOTHIES, ICED COFFEE/TEA'S, NATURAL JUICES, LIQUID YOGURTS, AND MORE.
- ✓ SUPPORTS THE PROMOTION OF HEALTHIER DRINK CHOICES FOR FAMILIES.
- ✓ SERVES DRINKS ICE COLD AND CAN BE USED TO SUPPORT OTHER DRINK MACHINES BY IMPROVING YIELD WHILE LOWERING ENERGY USAGE.

Regarding A Draft Milk Systems Points of Difference



“Putting a **chill on milk....Straight out of the box.”**

- Specialized Dispensing Towers assures that drinks are cold in the product holding area. (patent pending)
- Utilizes 50 plus years of proven low maintenance glycol refrigeration.
- Simple ratio-mix flavoring component creates flavored drinks for dispense.
- Real bulk drink delivery from bag n box – different box sizes, multi-box series, and compatible with other types of beverage containers.

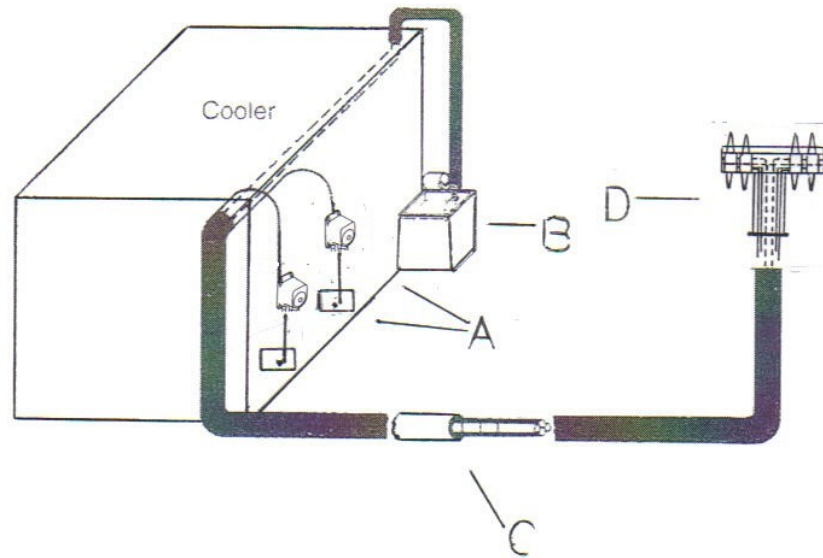

- A . Beverage Pumps
- B. Refrigeration Unit
- C. Trunk Housing
- D. Draught Milk Tower

- Supports a direct “on the spot” brand/product marketing strategy.
- Maximum dispensing impact with minimal space requirements.
- New opportunities for promoting and the expansion of new milk sales outlets.
- Milk, a health conscious drink should benefit by improved recognition and sales where people on the run assemble.



ANSI Standard 18 – Bulk General Dispensing
ANSI Standard 20 – Bulk Milk Dispensing

Robinson/Kirshbaum
Industries, Inc.
310-354-9948

Retailer Advantages With Draft Milk Systems

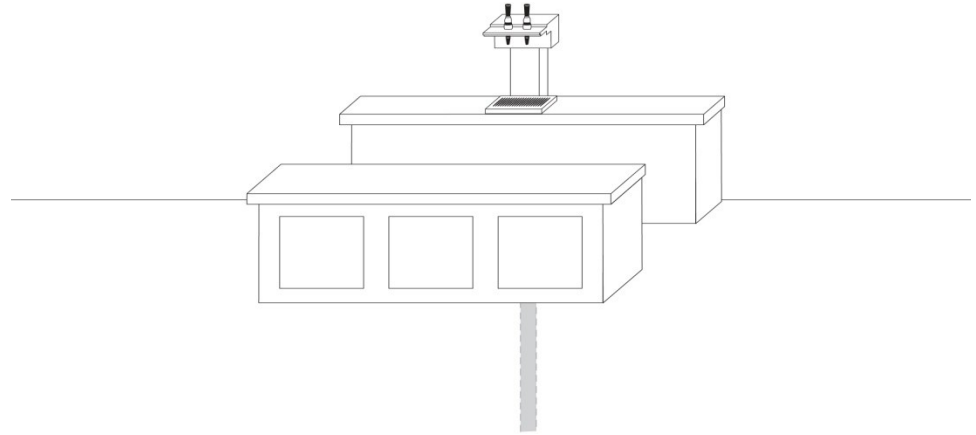

ATTRACTS THE HEALTH CONSCIOUS AND THE CURIOUS WHILE CREATING LOYAL CUSTOMERS THAT CAN BUILD YOUR ESTABLISHMENT A HIGHER VISIT FREQUENCY

WHEN CONSIDERING THE EASE OF STORAGE AND HANDLING OF BULK PACKAGING OR SERVING RATIO-MIXED FLAVORED BEVERAGES THAT CAN ASSIST IN INCREASING VOLUME SALES, BOOSTING PROFITS BECOMES CLEAR

HELPS PROMOTE BUSINESS BY ATTRACTING AND FOCUSING CUSTOMER ATTENTION THAT SPEEDS UP SELECTION BY SIMPLIFYING PRODUCT CHOICE WHILE UTILIZING A MINIMAL SPACE REQUIREMENT FOR IN-STORE DISPLAY

MULTI-BEVERAGE CAPABILITY INCREASES DRINK SALES POSSIBILITIES WHILE FREEING UP VALUABLE COOLER DISPLAY SPACE FOR OTHER TYPES OF FOOD RESOURCES

OFFERS BENEFITS THAT PROTECTS EMPLOYEES FROM HEALTH RELATED ISSUES LIKE REPETATIVE MOTIONS THAT OFTEN LEAD TO INJURIES, DOWN TIME, INSURANCE AND WORKERS COMP CLAIMS THAT COST OPERATIONS VALUED PROFITS

PROMOTES A LOWERED IMPACT ON THE ENVIRONMENT – FEWER DELIVERIES, LESS POWER USED, MINIMAL TRASH GENERATED = GREEN RECOGNITION AND CARBON TRADING POSSIBILITIES



“Putting a **chill** on milk....Straight out of the box.”



Robinson/Kirshbaum
Industries, Inc.
310-354-9948

Old Ideas With New Approaches Expands Sales

Bulk bag n box container use takes full advantage of their true storage and delivery capability while keeping within the concepts of Green technology.

Air is a renewable gas source to pressurize the beverage pumps with the support of the Excel-Air Compressor.

Keep beverage box changes in the back of the house, out of sight while keeping your valued customer out of harms way and your employee's safer.

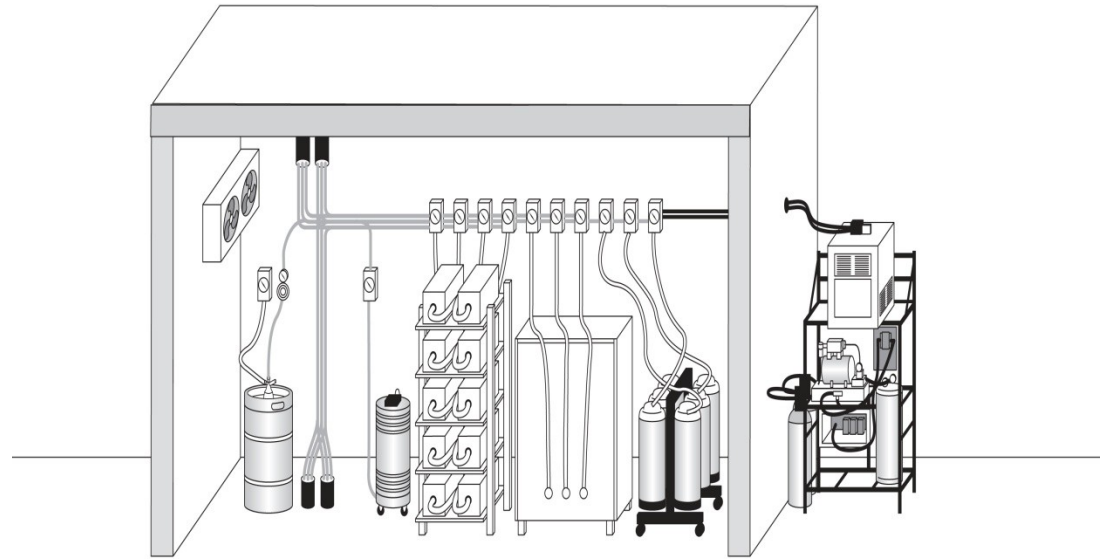

Refrigerated remote draught systems enables milk and other beverages to be delivered and dispensed cold almost anywhere.

Flavored dairy products can now be cost-effectively dispensed, building healthy drink choices while cutting labor and lowering landfill wastes.

Customer chooses drink size increasing potential of beverage volume sold and improving profits.

Dispensing towers that offer a "clean line of sight" can replace boring bulky counter-top dispensing units.



" Putting a *chill* on milk....Straight out of the box."



Robinson/Kirshbaum
Industries, Inc.
310-354-9948

Military Operations With Draft Milk Systems



Standard 20 – Bulk Milk Dispensing
Standard 18 – General Beverage Dispensing

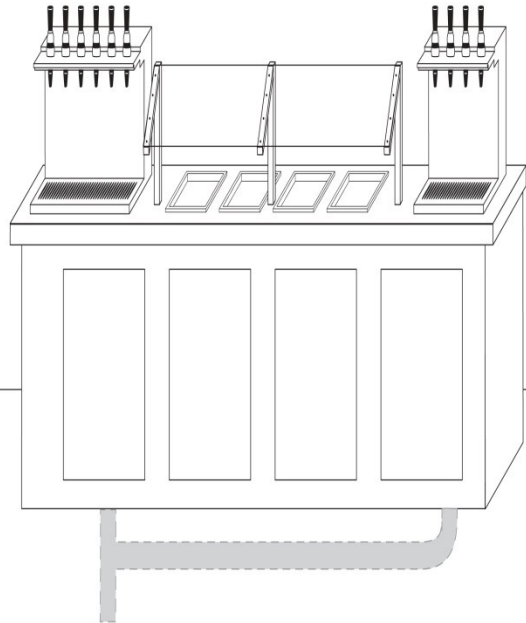

1. Benefits all branches of the military.
2. Applications regarding land and sea for commissaries, mess halls to portable field operations.
3. Can efficiently serve thousands of soldiers quickly and with less handling.
4. Utilizes multiple 5 gallon Bag n Box containers in a daisy chain series or larger capacity sized BIB containers.
5. Capable of ratio mixing flavorings in to base milks that can enhance a soldier's meal experience.
6. Maintains the temperature of milk products to enhance their quality for optimum taste and shelf life, dispensing as cold as 32 to 35 degrees.
7. All types of drinks served in a smaller space requirement.
8. With remote draft milk systems, there is no more need to disrupt serving lines as all beverage handling is done behind the scenes away from your serving operations.
10. Can re-constitute concentrate milk, add flavoring if required, transport, then dispense the finished drink.
12. Aseptic milk and non-milk related drinks are no problem.
11. With our Sub Arctic Chill Plate we can flash chill the beverage products quicker for dispensing in a hurry.
12. Uses proven remote draft dispensing technology that has been around for 50 plus years in the beer industry.